

Énigme niveau 1

Colorie les pots de fleurs en rouge, jaune et bleu.

Le petit jardinier veut peindre ses pots de fleurs en rouge, jaune et bleu.

Trouve 2 autres possibilités :

Attention : Il ne faut pas utiliser 2 fois la même couleur, l'ordre des couleurs étant différent à chaque fois.

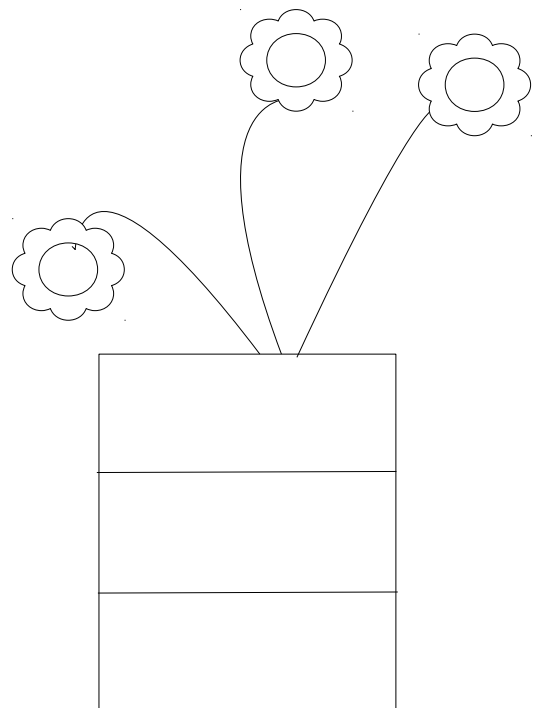
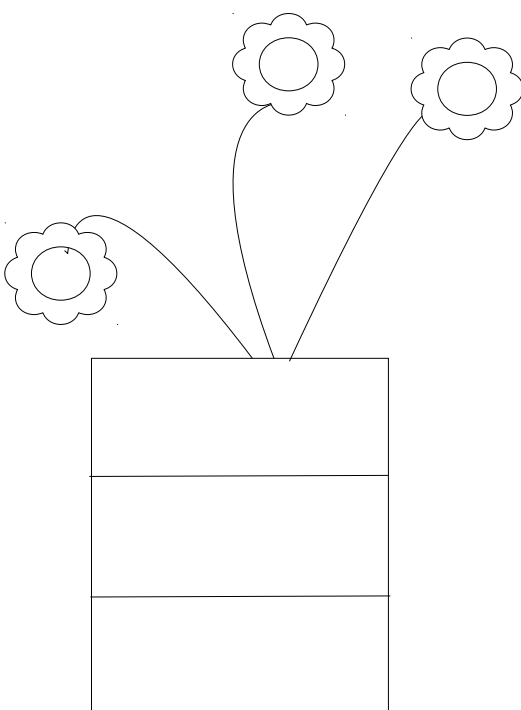
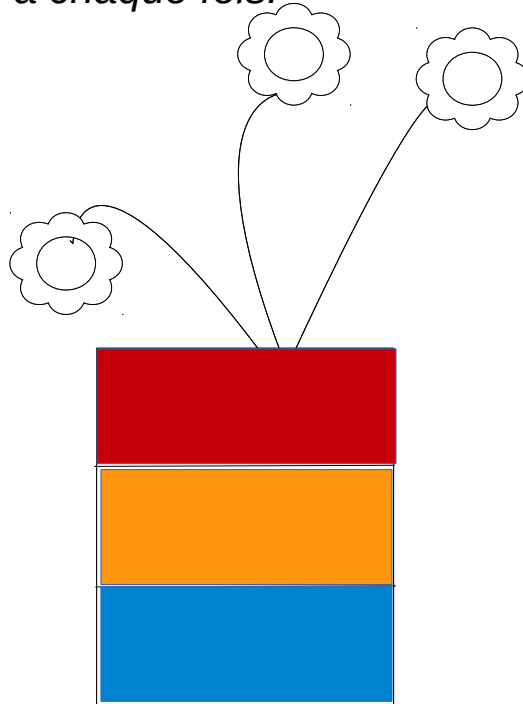

Énigme niveau 1

Colorie les pots du petit jardinier

Le petit jardinier veut peindre ses pots de fleurs en rouge, jaune et bleu.

Trouve 2 autres possibilités :

Attention : Il ne faut pas utiliser 2 fois la même couleur, l'ordre des couleurs étant différent à chaque fois :

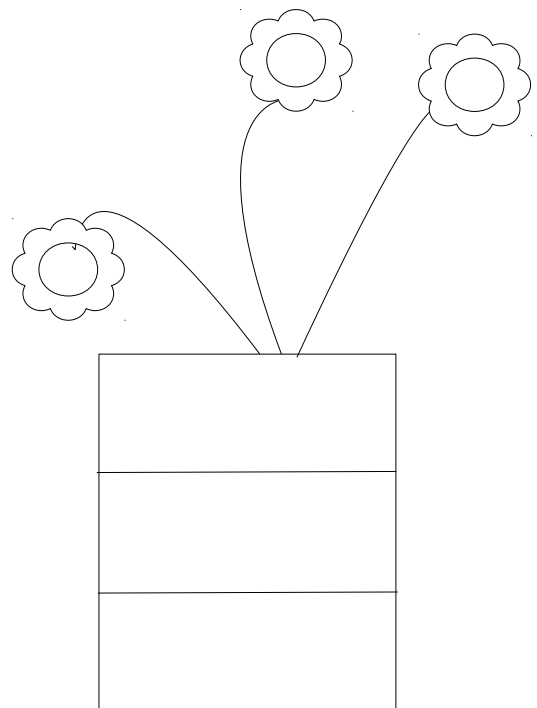
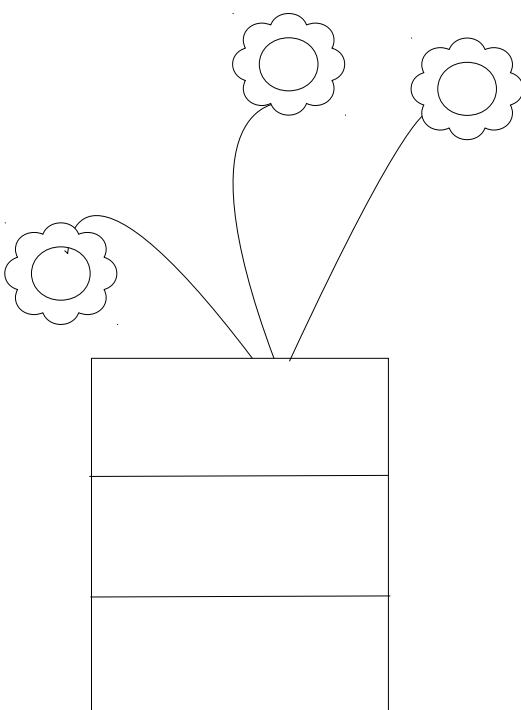
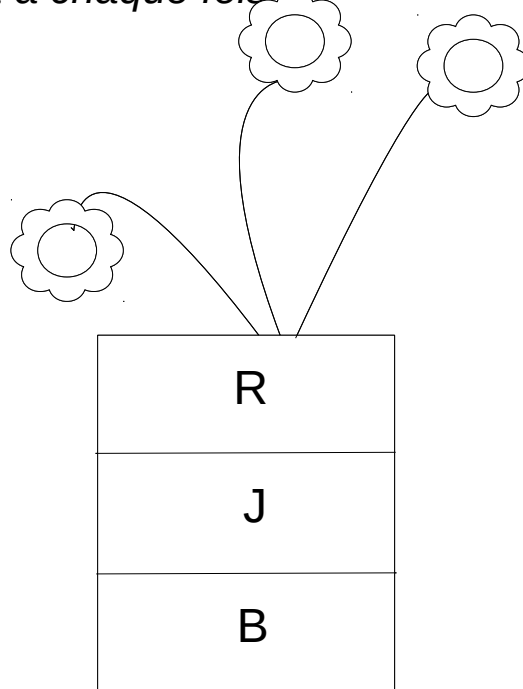

Énigme niveau 1

Colorie les pots du petit jardinier

Le petit jardinier veut peindre ses pots de fleurs en rouge, jaune et bleu.

Trouve 2 autres possibilités :

Attention : Il ne faut pas utiliser 2 fois la même couleur, l'ordre des couleurs étant différent à chaque fois :

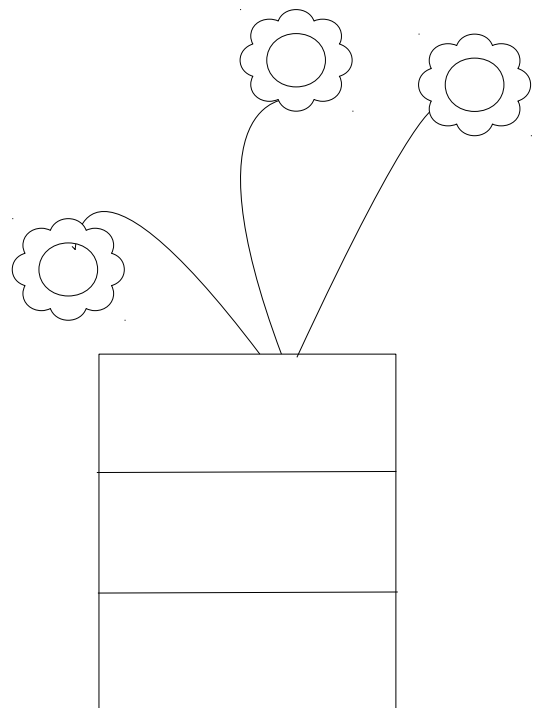
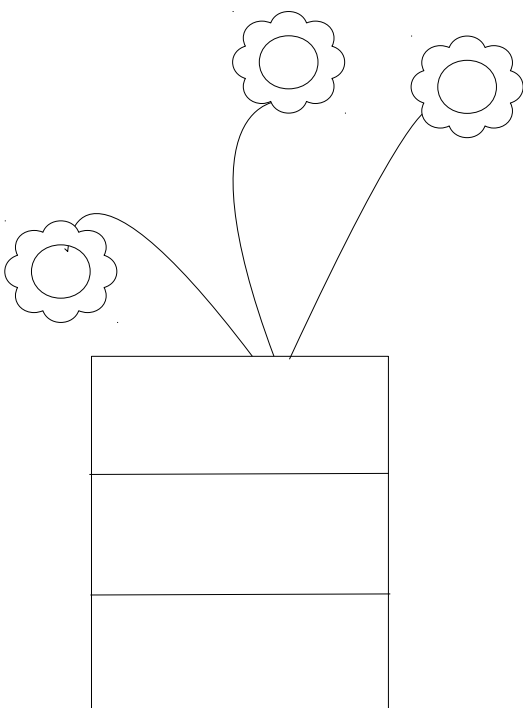
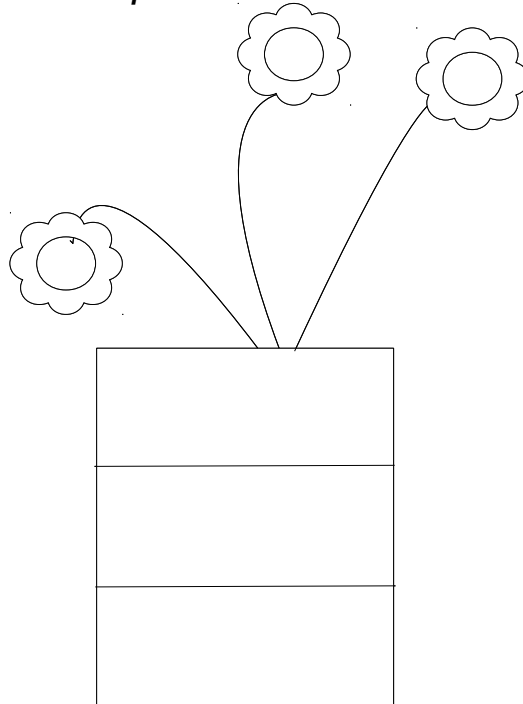

Énigme niveau 2

Colorie les pots du petit jardinier

Le petit jardinier veut peindre ses pots de fleurs en rouge, jaune et bleu.

Trouve les 6 possibilités :

Attention : Il ne faut pas utiliser 2 fois la même couleur, l'ordre des couleurs étant différent à chaque fois.

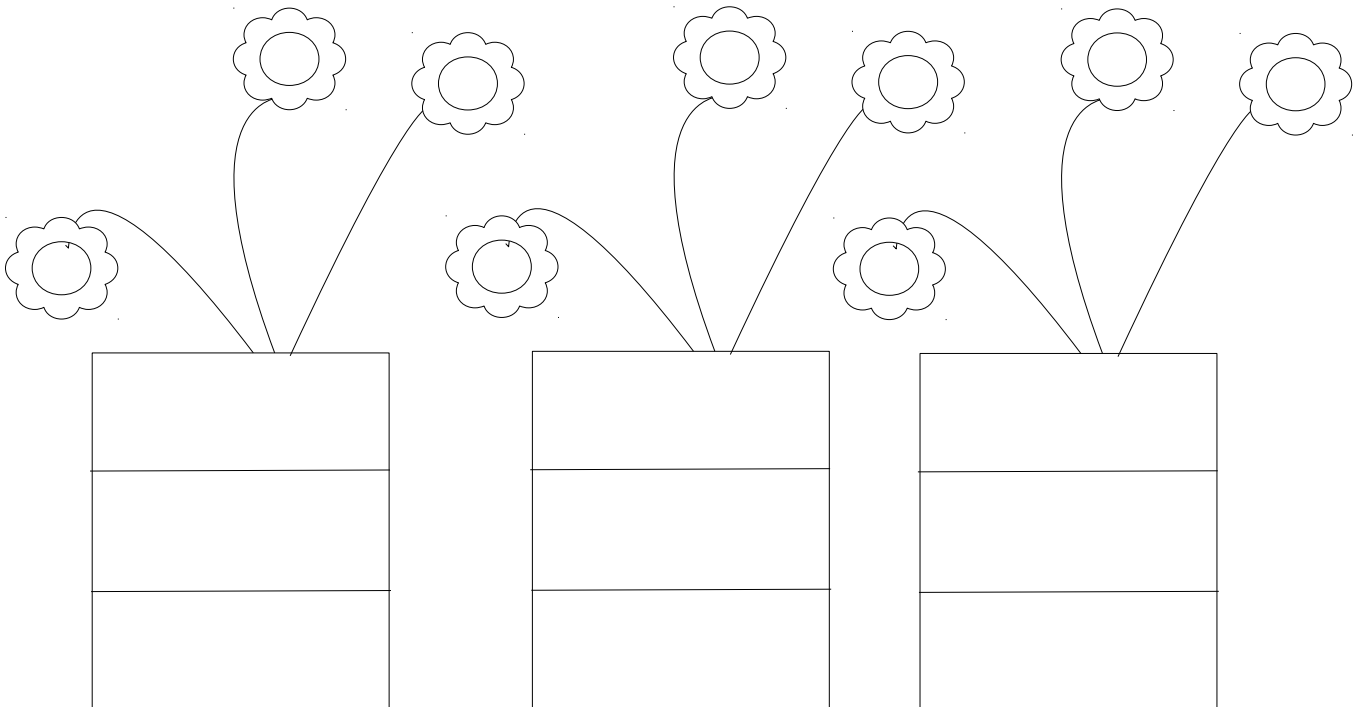
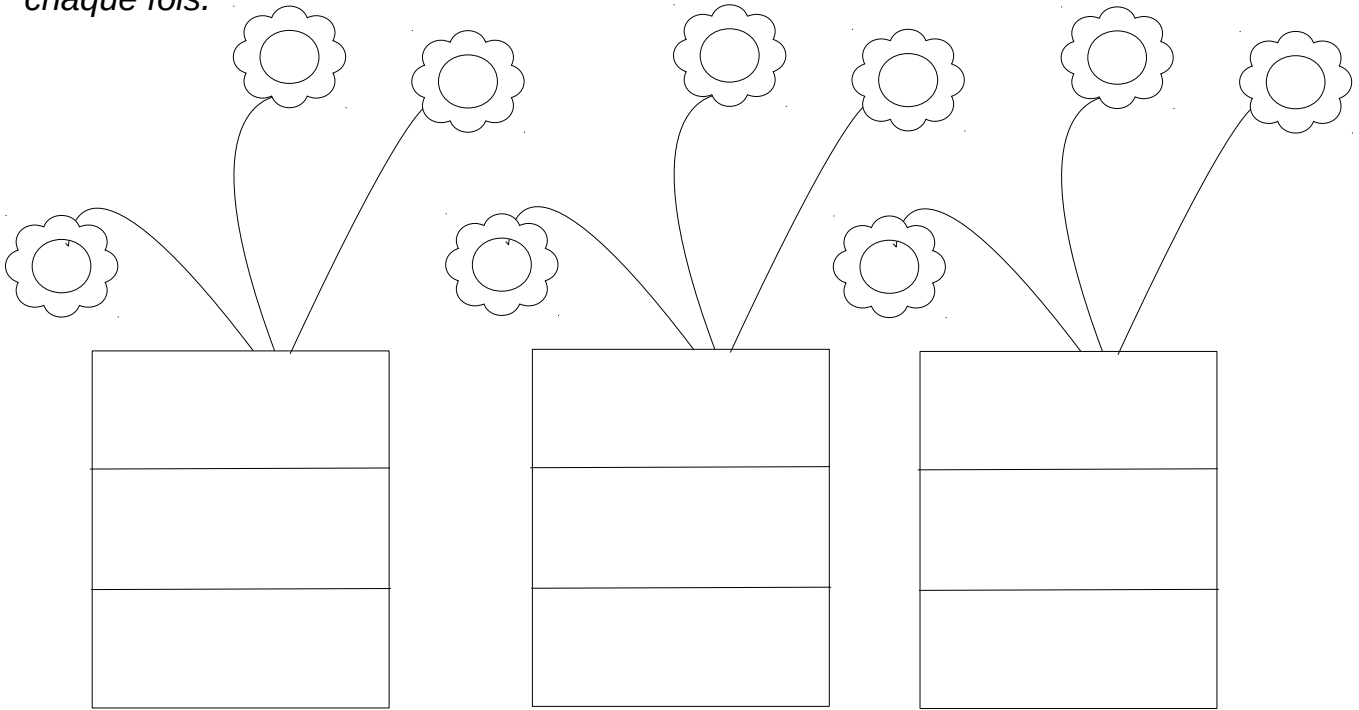

Bandes pour les énigmes niveaux 1 et 2 :



Bandes à colorier pour les énigmes niveaux 1 et 2 :

R

J

B

R

J

B

R

J

B

R

J

B

R

J

B

R

J

B

R

J

B

R

J

B

Bandes à colorier pour les énigmes niveaux 1 et 2 :

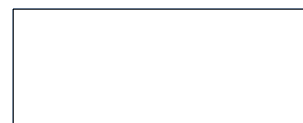
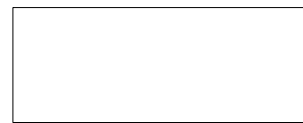
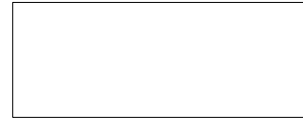
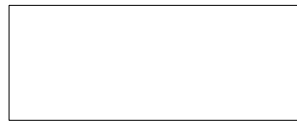
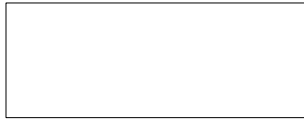

Énigme niveau 3

Colorie les pots du petit jardinier

Le petit jardinier veut peindre ses pots de fleurs en rouge, jaune, vert et bleu.

Trouve les 24 possibilités :

Attention : Il ne faut pas utiliser 2 fois la même couleur, l'ordre des couleurs étant différent à chaque fois. Il y a 4 couleurs de bandes différentes.

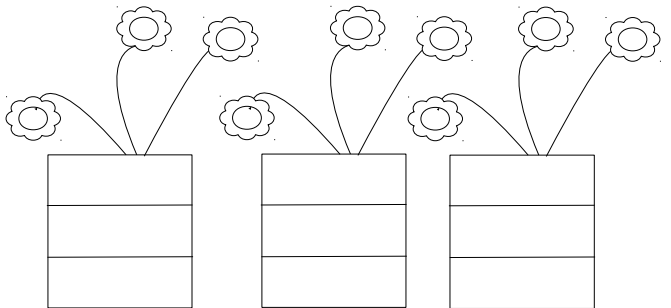
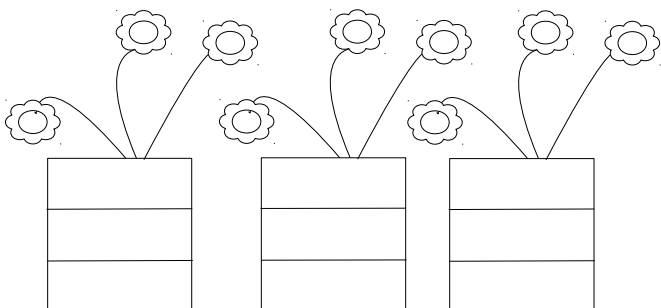
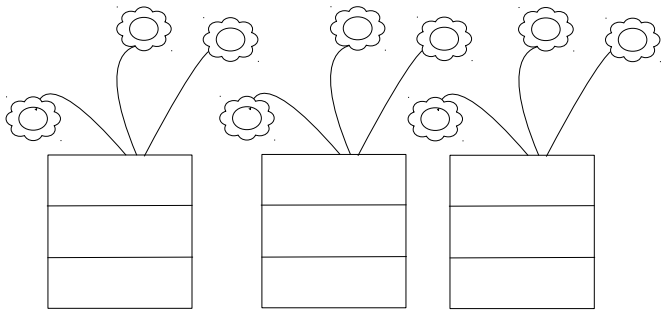
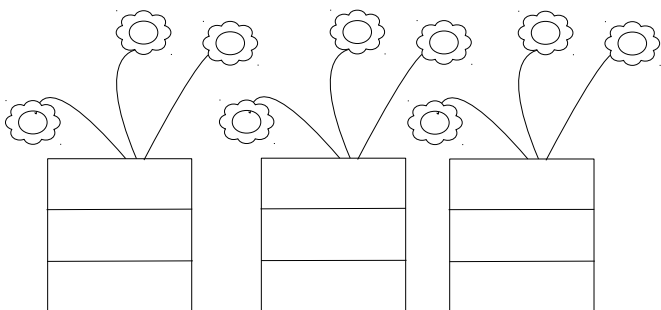
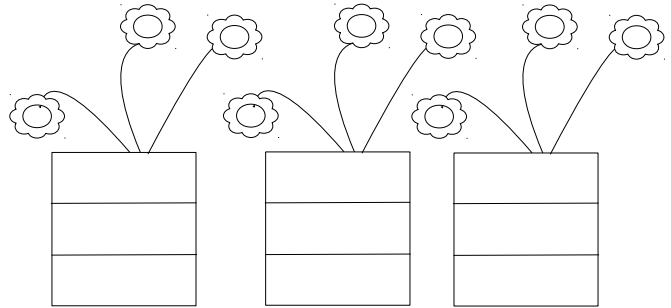
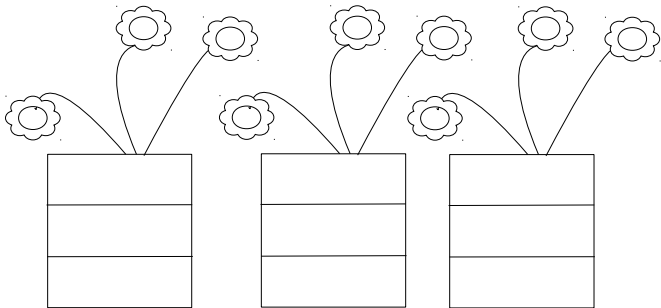
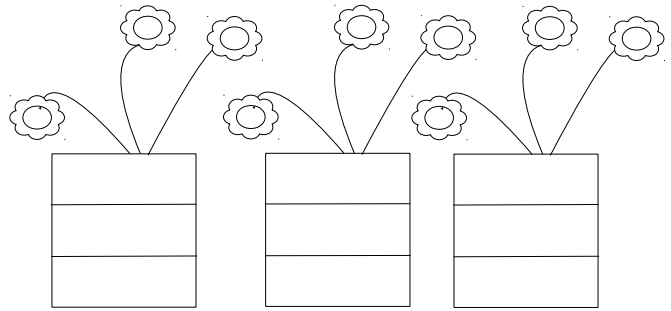
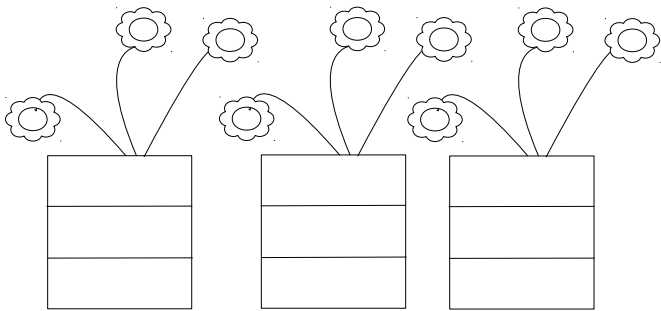

Énigme niveau 4

Colorie les pots de fleurs du petit jardinier

Le petit jardinier veut peindre ses pots de fleurs en rouge, jaune, vert et bleu.

Trouve les 18 possibilités :

Attention : Il ne faut pas utiliser 2 fois la même couleur, l'ordre des couleurs étant différent à chaque fois. La bande bleue ne pourra pas être au milieu. Il y a 4 couleurs de bandes différentes.

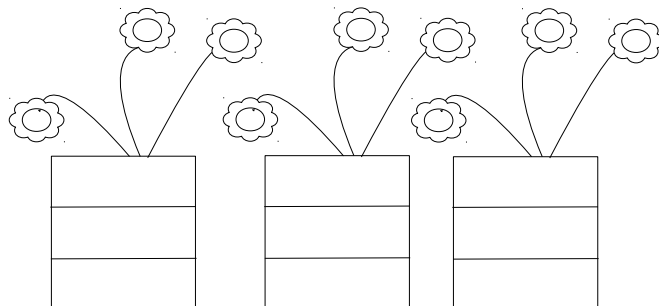
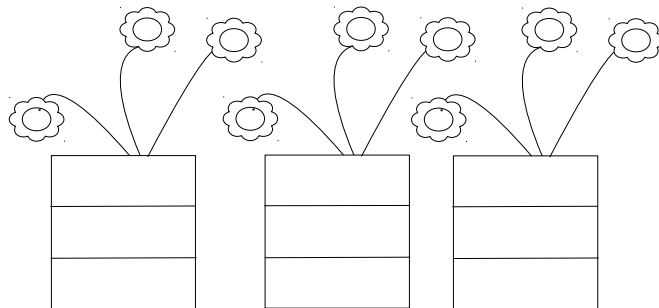
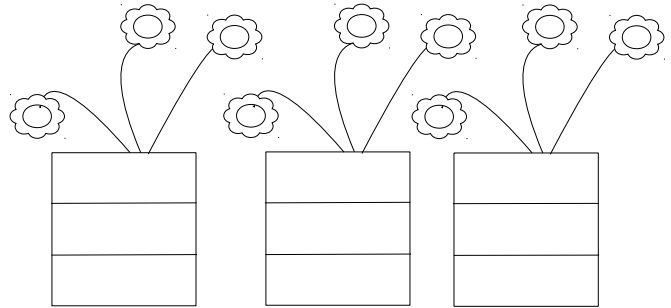
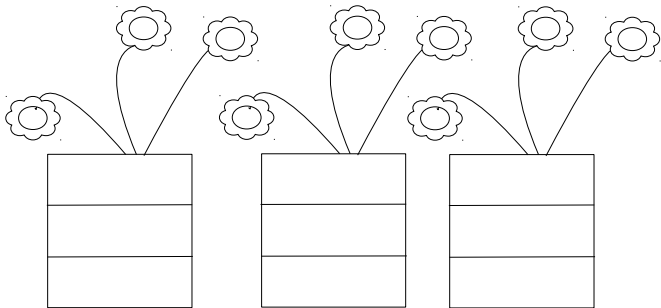
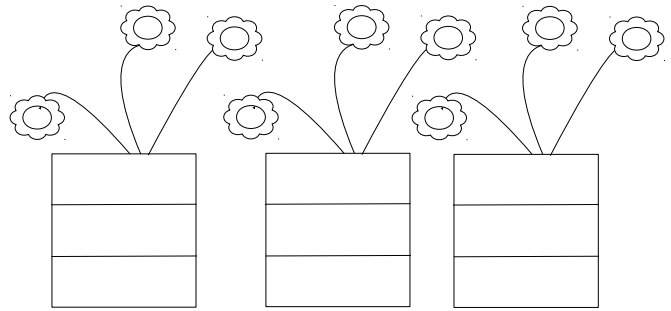
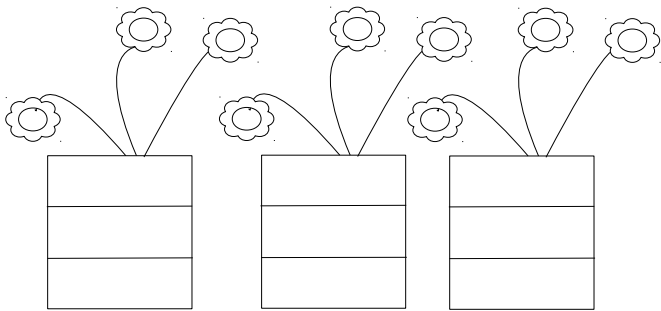

Énigme niveau 5

Colorie les pots du petit jardinier

Le petit jardinier veut peindre ses pots de fleurs en rouge, jaune, vert et bleu.

Trouve les 24 possibilités :

Attention : Il faut trois couleurs différentes sur chaque pot (l'ordre des couleurs étant différent à chaque fois). Trouve les pots manquants et enlève les doubles.

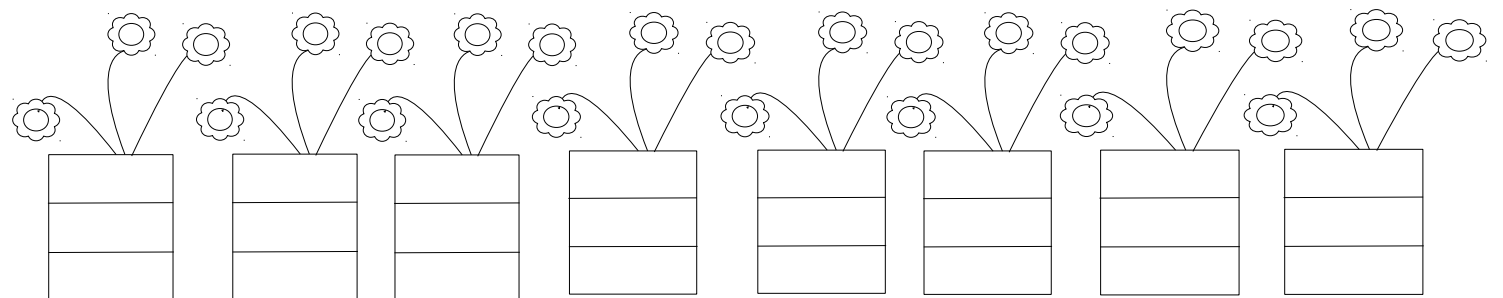
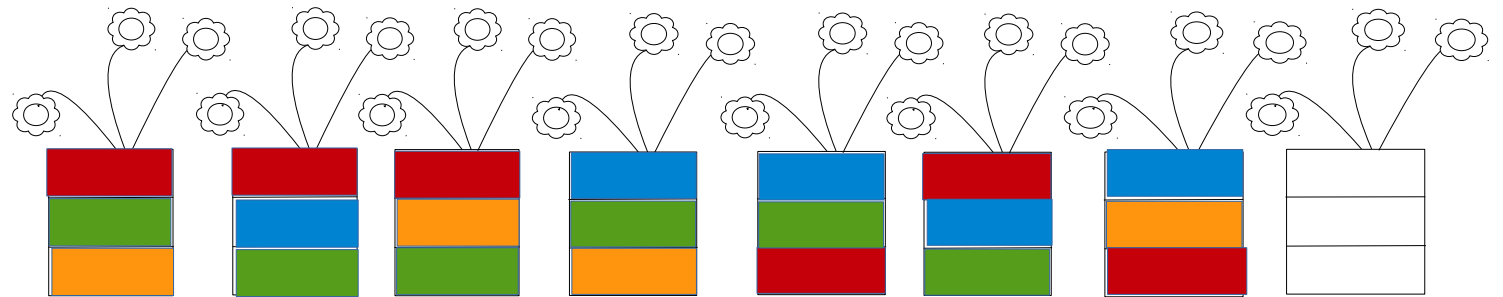
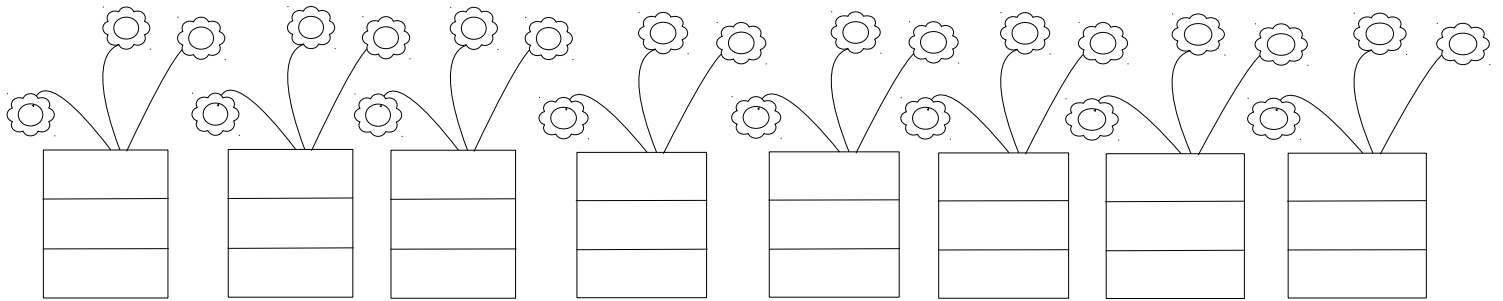
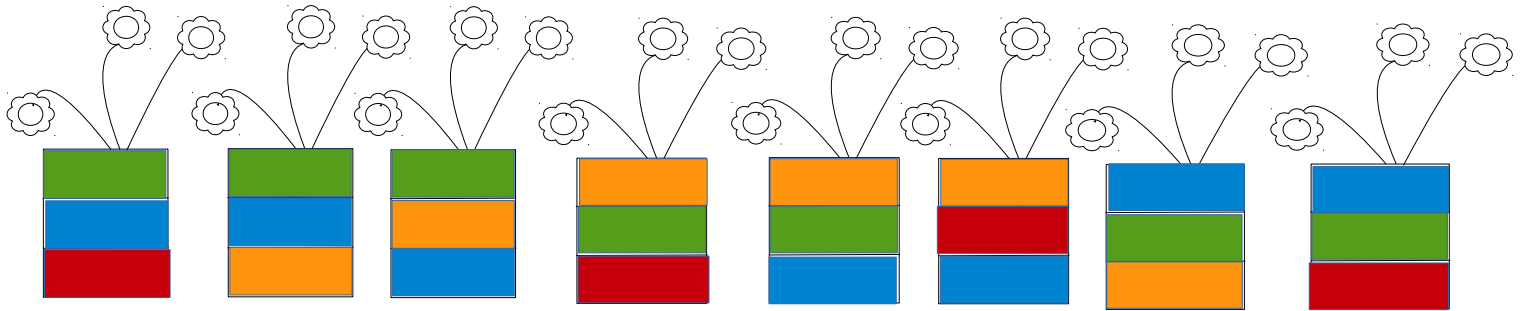

Bandes pour les énigmes niveaux 3, 4 et 5 :



Bandes à colorier pour les énigmes niveaux 3, 4 et 5 :

R J B V

R J B V

R J B V

R J B V

R J B V

R J B V

R J B V

R J B V

R J B V

R J B V

R J B V

R J B V

R J B V

R J B V

R J B V

R J B V

R J B V

R J B V

R J B V

R J B V

R J B V

R J B V

R J B V

R J B V

R J B V

R J B V

R J B V

R J B V

R J B V

R J B V

R J B V

R J B V

R J B V

R J B V

R J B V

R J B V

R J B V

R J B V

Énigme niveau 6

Colorie les pots du petit jardinier

Le petit jardinier veut peindre ses pots de fleurs en rouge, jaune et bleu.

Trouve les 18 possibilités :

Attention : Il ne faut pas de couleur identique qui se touche, l'ordre des couleurs étant différent à chaque fois.

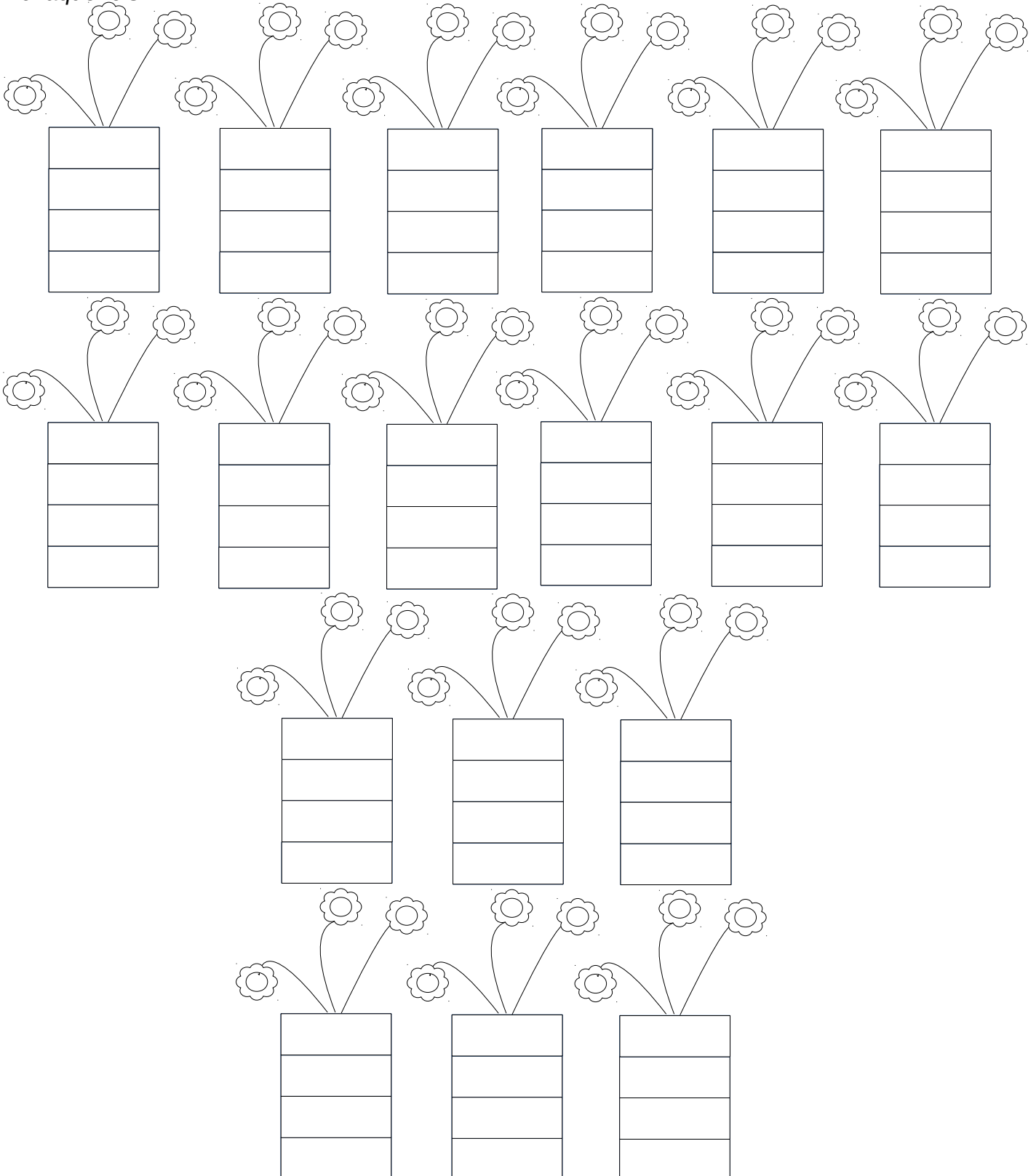

Bandes pour l'énigme niveau 6 :

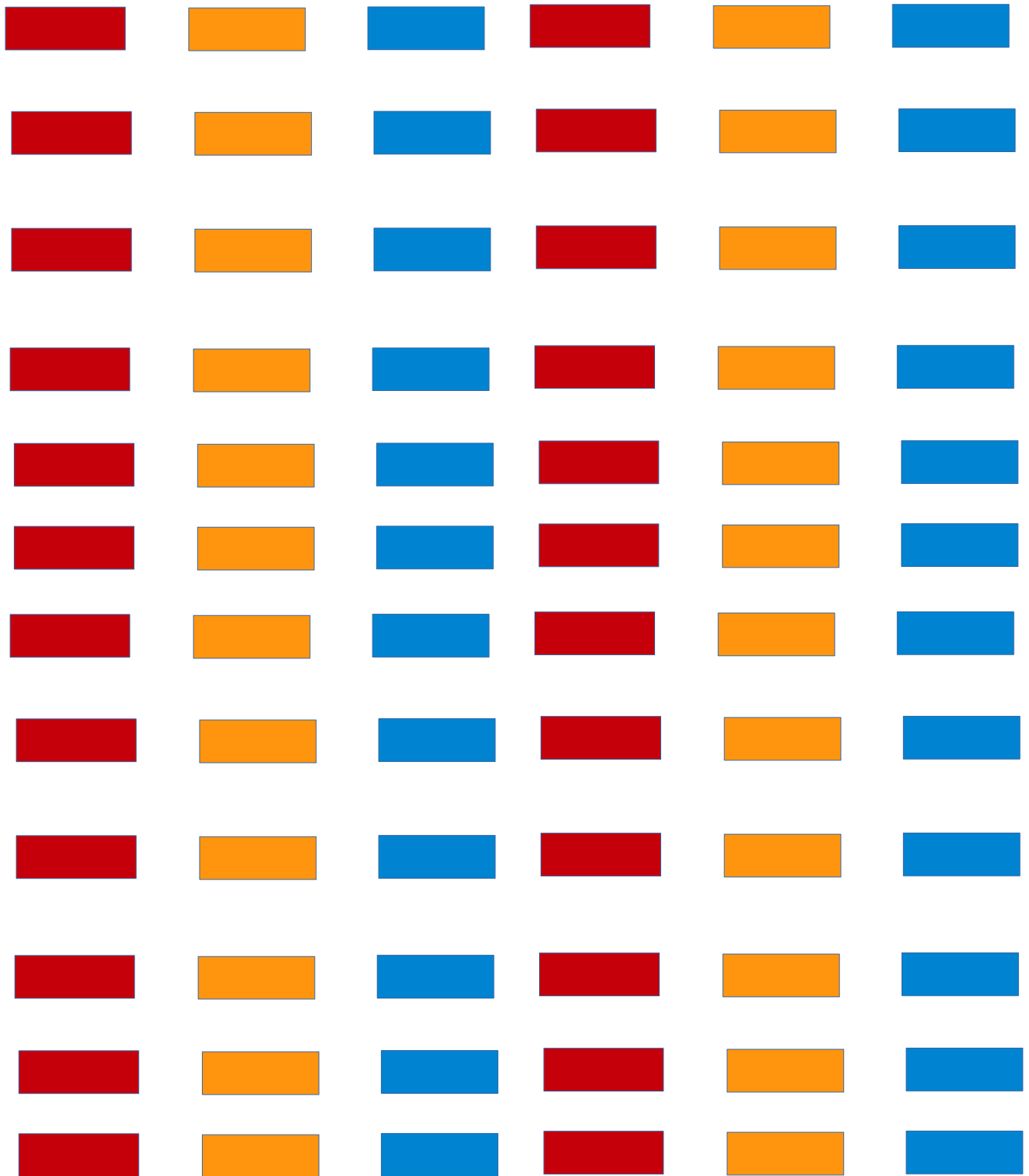

Bandes à colorier pour l'énigme niveau 6 :

R

J

B

R

J

B

R

J

B

R

J

B

R

J

B

R

J

B

R

J

B

R

J

B

Bandes à colorier pour l'énigme niveau 6 :

